

# MARKETING POLITIK



**Yuswohady**

**Chief Executive – MarkPlus Institute of Marketing**

**Makasar, 7 Maret 2009**

# Learning from Obama



# Learning from Obama

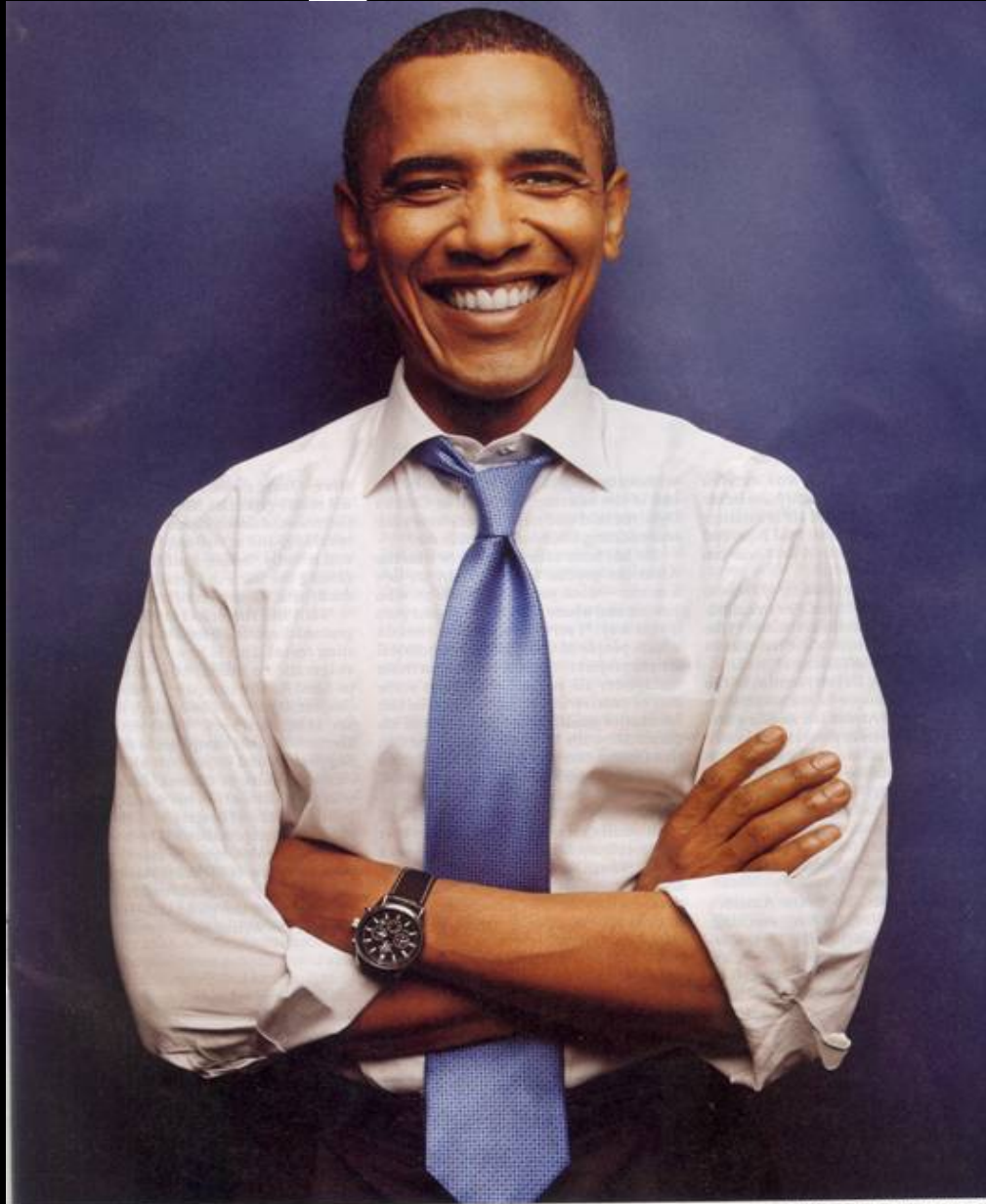

Photographs by Ben Baker—Re

# Learning from Obama



**When you look at this photo, what do you see?**

- 1. Black Man
- 2. Healer
- 3. Novice
- 4. Radical
- 5. The Future
- All of the above

**Your answer, explained.**

**The Five Faces Of Barack Obama**

BY DAVID VON DREHLE

# My.BarackObama.com

Get Local! Create Your MyBO Account ( [or Login](#) )

[EN ESPAÑOL](#)



**"I'M ASKING YOU TO BELIEVE.**  
Not just in my ability to bring about  
real change in Washington ... I'm  
asking you to believe in yours."

GET INVOLVED NOW

FIND AN EVENT  
NEAR YOU

[LEARN](#) [ISSUES](#) [MEDIA](#) [ACTION](#) [PEOPLE](#) [STATES](#) [BLOG](#) [STORE](#)

BECAUSE IT'S ABOUT  
**YOU**



*Our online tools make  
local organizing easy*

*Create Your Account*

**Melalui [My.BarackObama.com](http://My.BarackObama.com)  
Obama mengumpulkan hampir 1 miliar  
dolar dana kampanyenya dari **JUTAAN**  
donatur "gurem" yang bisa menyumbang  
hanya 5 dolar per orangnya**

**WOW... THAT'S GRASS ROOT MARKETING!!!**

# Obama at Facebook

facebook

Home

Profile

Friends

Inbox 2

Yuswo Hady

Settings

Logout

Search



Barack Obama

◀ Browse more Politicians



Country: United States

**Current Office**

Office: President-Elect

Become a Supporter

View Updates

Share +

### Favorite Pages

6 of 12 Pages

See All



Michelle Obama



Obama Pride



Joe Biden



Latinos for Obama



Obama



First Americans for Obama

### YouTube Box

2 of 41

See all

Applications



Online Friends (1)



## Obama at Facebook

Obama has 1.7 mio friends  
in Facebook

McCain has 550.000 friends  
in Facebook

October 2008

# Obama at YouTube

**You Tube** Broadcast Yourself™  
Worldwide | English

(0) **yuswohady** ▾ | Account | QuickList (0) | Help | Sign Out

[Home](#) | [Videos](#) | [Channels](#) | [Community](#)

▾

## Barack Obama YouTube Spotlight



**OBAMA BIDEN**

**BarackObamaDotcom**  
June 13, 2007  
[\(more info\)](#)

How Can We Make this Country Better? We want to hear your ideas - visit [www.barackobama.com/youtube](http://www.barackobama.com/youtube)

URL

Embed

- ▼ **More From: BarackObamaDotcom**
- Election Day Voices in Grant Park**  
205,425 views  
BarackObamaDotcom
  - President-Elect Barack Obama on Election Night**  
727,556 views  
BarackObamaDotcom
  - Bruce and Barack: The Rising in Cleveland**  
76,835 views

Rate: ★★★★★ 2,594 ratings Views: 754,810

# Senjata Pamungkas Obama: Blackberry



Why choose  
If you can  
combine?

Why  
choose  
if you can  
combine?

Go study at HUB.  
The first college and university in one.

Pass by on our infodays. More info at [www.hubnussel.be](http://www.hubnussel.be)



part of  
Hogeschool Brussel

**CAPRES**

**GO**

**HORIZONTAL**

# Politician Goes Horizontal...

facebook

Home Profile Friends Inbox 32

Yuswo Hady Settings Logout

Search



H. WIRANTO, SH  
KETUA UMUM

- View Photos of 'Wiranto' (51)
- View Videos of 'Wiranto' (3)
- Send 'Wiranto' a Message
- Poke 'Wiranto'

## Information

Networks:  
Indonesia

Relationship Status:

## 'Wiranto Partai Hanura'

Wall Info Photos Boxes

Write Share Link Post Photo Causes Record Video

Write something...

Post

All Posts Posts by 'Wiranto' Posts by Others Wall-to-Wall

Yesterday



**Rachmad K Dwi Susilo** wrote at 7:18pm  
gimana, Pak. Larinya kurang cepet nih...ambil simpati publik for president



**Bung Mansur** tagged 'Wiranto in a photo. 2:133pm  
Tagged in:  
Bung Mansur Events in Jakarta



**Yudhi Yudhi** tagged 'Wiranto in a photo. 10:17am  
Tagged in:  
Alumni Budi Mulia Bogor [Kamus 22]



Advertise

## Permainan Online



Daftar!



## Are You A Gamer?



Real time online space game!  
No downloads - start playing  
online right now. 100% free.



# Politician Goes Horizontal...

facebook

Home

Profile

Friends

Inbox 32

Yuswo Hady

Settings

Logout

Search



Prabowo Subianto

Wall

Info

Photos



Write



Share Link



Post Photo



Causes



Record Video



Write something...

Post

View Photos of Prabowo (129)

View Videos of Prabowo (12)

Send Prabowo a Message

Poke Prabowo

Saat ini kapasitas Friends saya sudah mencapai limit. Saya minta kesediaan teman-teman untuk menjadi supporter saya dan berdiskusi bersama di <http://tinyurl.com/prabowo> dan remove saya menjadi teman sehingga teman-teman yang lain bisa saya confirm.

## Information

Relationship Status:

Single

Birthday:

All Posts

Posts by Prabowo

Posts by Others

Wall-to-Wall

Today



Prabowo is now friends with Mochamad Isnaeni Ramdhan. 12:09am - Comment

Yesterday



**Norman Rinaldy Mokoginta wrote** at 10:49pm

Pak Prabowo for President !!!!!..Bawa bangsa kita menemukan lagi harga diri kita sebagai bangsa besar dan jaya !!!! Indonesia harus kembali menjadi Macan Asia !!!



Prabowo is now friends with Mohd Fauzan Hanafi. 9:43pm - Comment



**Niendita Adriawardhani wrote** at 6:42pm

GERINDRA iklan nya keren...  
temen2 saya semuanya nge Fans sm ikannya! hehehehe



**Ferdinand Darmawan wrote** at 6:17pm

Berdiri Tidak Hanya untuk saat ini.. Hidup pak Prabowo...

Advertise

Specials On Asia Hotels



Asiarooms.com number 1 in Asia hotels! Special hotel rate deals in Thailand, Indonesia, Malaysia, Australia, Japan, China, HK and NZ.



Math Practice is Fun



Are you the parent of a 5-to-11-year-old? Try the best math practice site! With

Applications



Taufik Nur Mas...

M Ario Adimas

Online Friends (15)



# Politician Goes Horizontal...

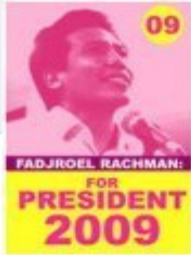

**Fadjroel Rachman** is Debat di TVOne tentang Fatwa Golput Haram versus Lukman Hakim Saefudin (PPP) pkl 19.00 dan diulang tengah malam. 4 hours ago

Wall Info Photos

Write Share Link Post Photo Causes Record Video

Write something... Post

All Posts Posts by Fadjroel Posts by Others Wall-to-Wall

Yesterday

Fadjroel is now friends with Diyon Agung Seda Nganggo. 10:42pm - Comment

**VIVANEWS** 10:29pm  
Source: video.vivanews.com



“ Pleno Capres Independen di MK (13 Januari 2009) ”

Comment - Share

**Sidang Perdana Uji Materil UU Pilpres oleh Wiranto Cs** 10:27pm  
Source: tv.kompas.com  
Kompas-TV.com :: On Line Indonesian News & Information on Video Streaming (Sandika Digital Media) ::

“ Sidang Capres Independen Fadjroel (24 Desember 2008) ”

Comment - Share

- View Photos of Fadjroel (3)
- View Videos of Fadjroel (2)
- Send Fadjroel a Message
- Poke Fadjroel

Ini adalah Facebook kedua dari FADJROEL RACHMAN karena yang pertama sdh penuh 5000 friends, yang sudah ada di FB1 tak perlu masuk friends di sini.tx

### Information

Relationship Status:  
**Married**

Birthday:  
**January 17**

Political Views:  
**Progressive Social Democracy**  
(Kejurusan Ulfasa-Cheba)

Advertise

**MusicStore.  
KapanLagi.com**



Kamu bisa beli musik online untuk didengerin di ponsel kamu atau di PC Windows Media. Bayar via SMS atau IVAS.



**Seeking Education  
Agents**



Welcome to the NEW WAVE era

CROWD

MARKETING  
BECOMES  
H O R I Z O N T A L

Your  
Customers  
Are  
Salesmen

Sebuah  
"Puisi Marketing"  
Karya  
**YUSWOHADY**  
Co-Author Buku Best Seller  
MARKETING IN VENUS

PENGANTAR  
HERMAWAN KARTAJAYA



**E**  
Marketing ENERGY

**=**

**w M C<sup>2</sup>**  
Word of MOUTH (MOUSE)

Customer  
COMMUNITY  
Offline  
Online

# VERTICAL

# HORIZONTAL

**1 to Many**  
**(Mass Marketing)**

**1 to 1**  
**(D-base Marketing)**

**Many to Many**  
**(Viral Marketing)**

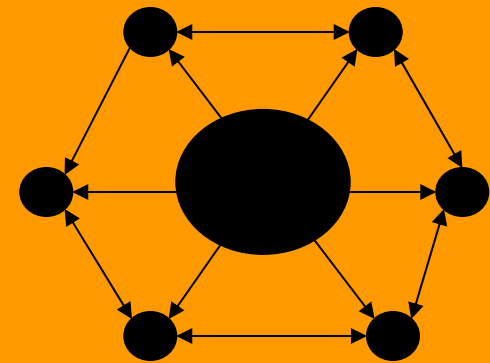
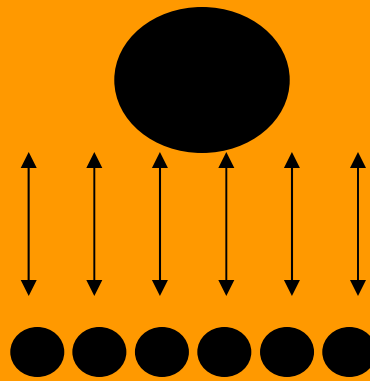
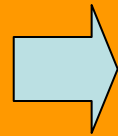
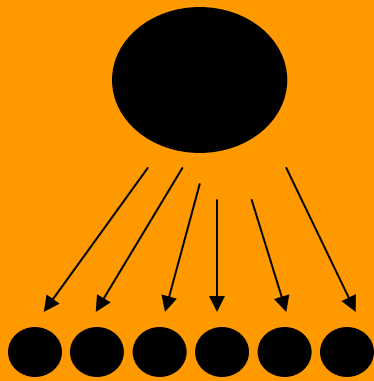

**Consumer Goods**  
i.e. Unilever

**Banks & Financials**  
i.e. Citibank

**Community-Driven Products**  
i.e. Facebook  
i.e. Harley Davidson

**Company as  
Broadcaster**



**Company as  
Partner**



**Company as  
Connector**

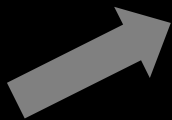
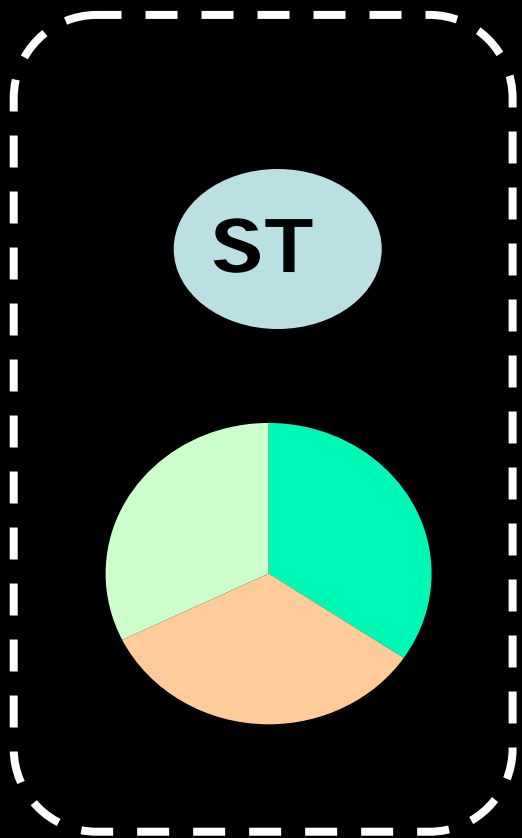

PDB

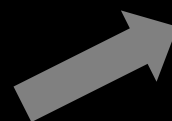
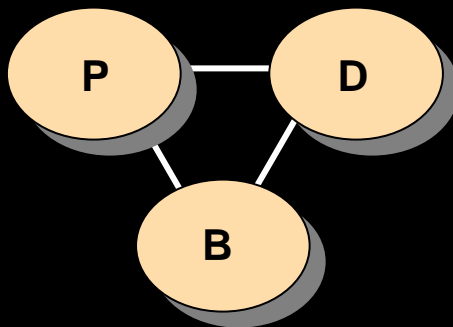

4P

P1	P2
P3	P4

## SEGMENTATION-TARGETING

**WHO ARE  
YOUR CORE  
TARGET  
AUDIENCE ?**



Be Rambo....

or

Good Sniper.??

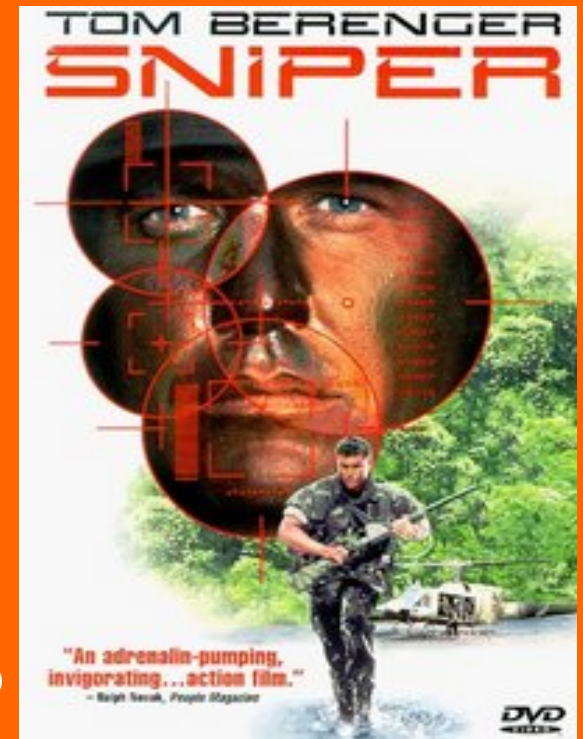



## Prabowo Subianto

Prabowo Subianto, Ketua Umum  
Himpunan Kerukunan Tani Indonesia  
(HKTI). Bian Harnansa/Persda Network  
14-02-2008

**WHO ARE  
THE TARGET  
AUDIENCE?**

**WHO ARE  
THE TARGET  
AUDIENCE?**



**WHO ARE  
THE TARGET  
AUDIENCE?**



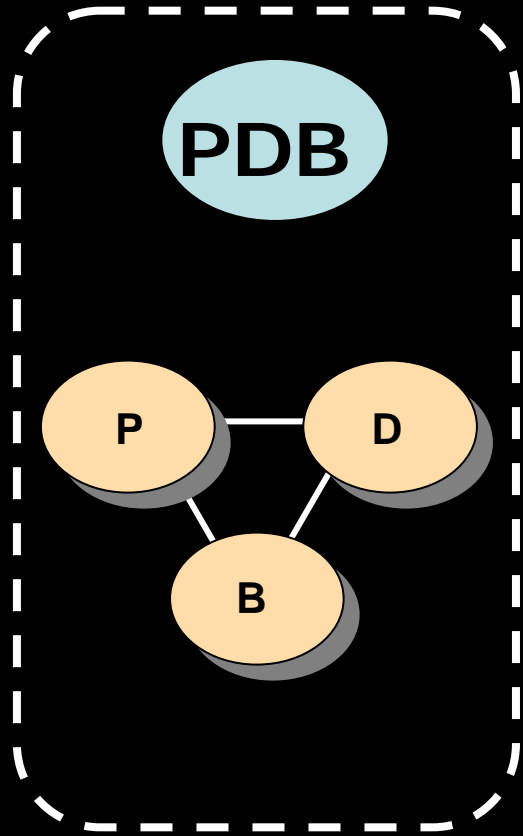
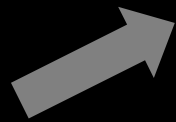
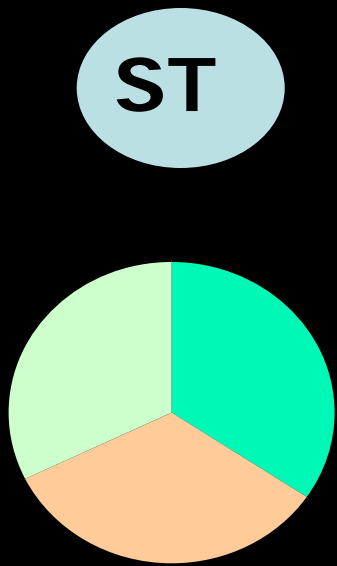

4P

P1	P2
P3	P4

# SEGITIGA PDB

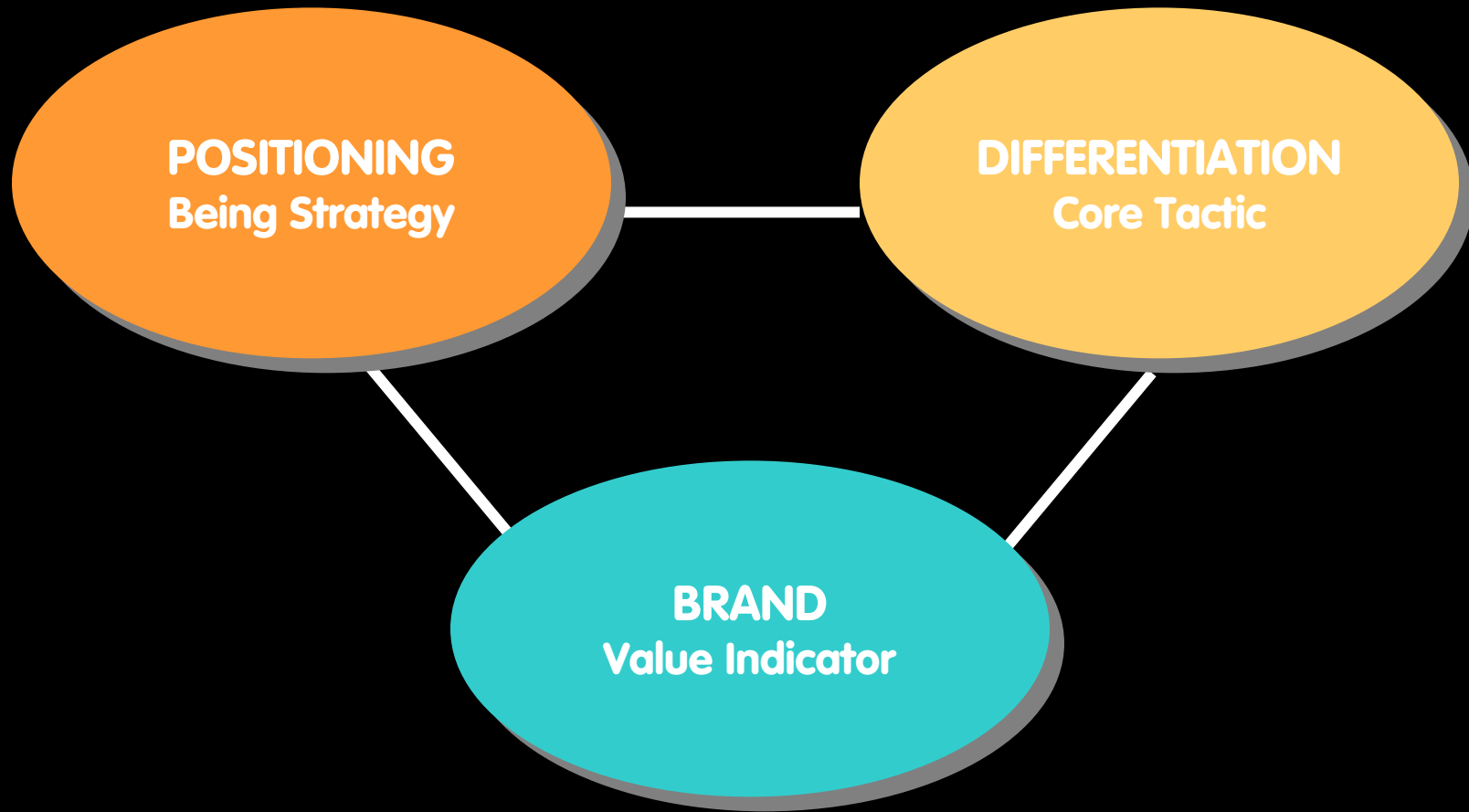

# SEGITIGA PDB

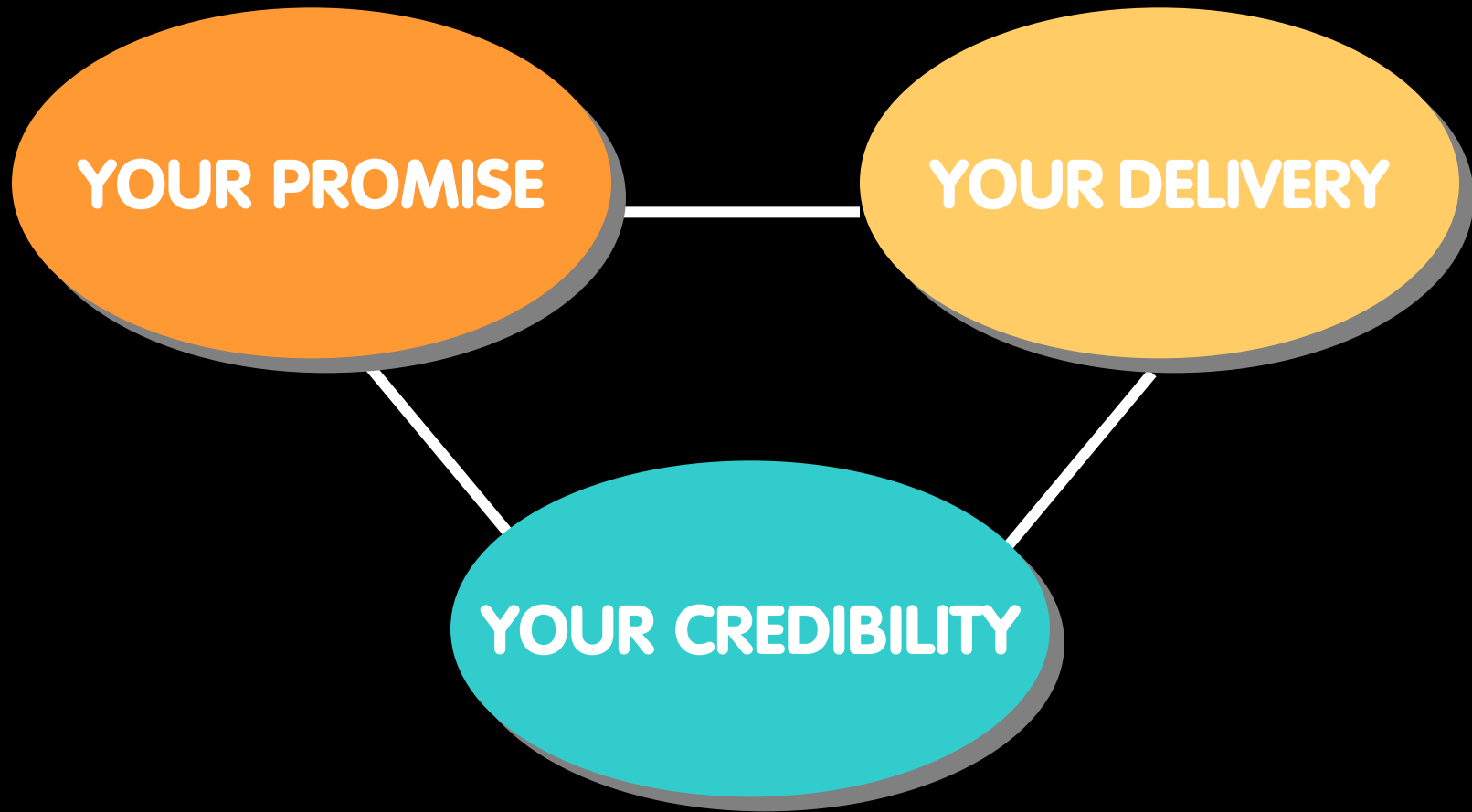

**BE**

**DIFFERENT**

# Prabowo

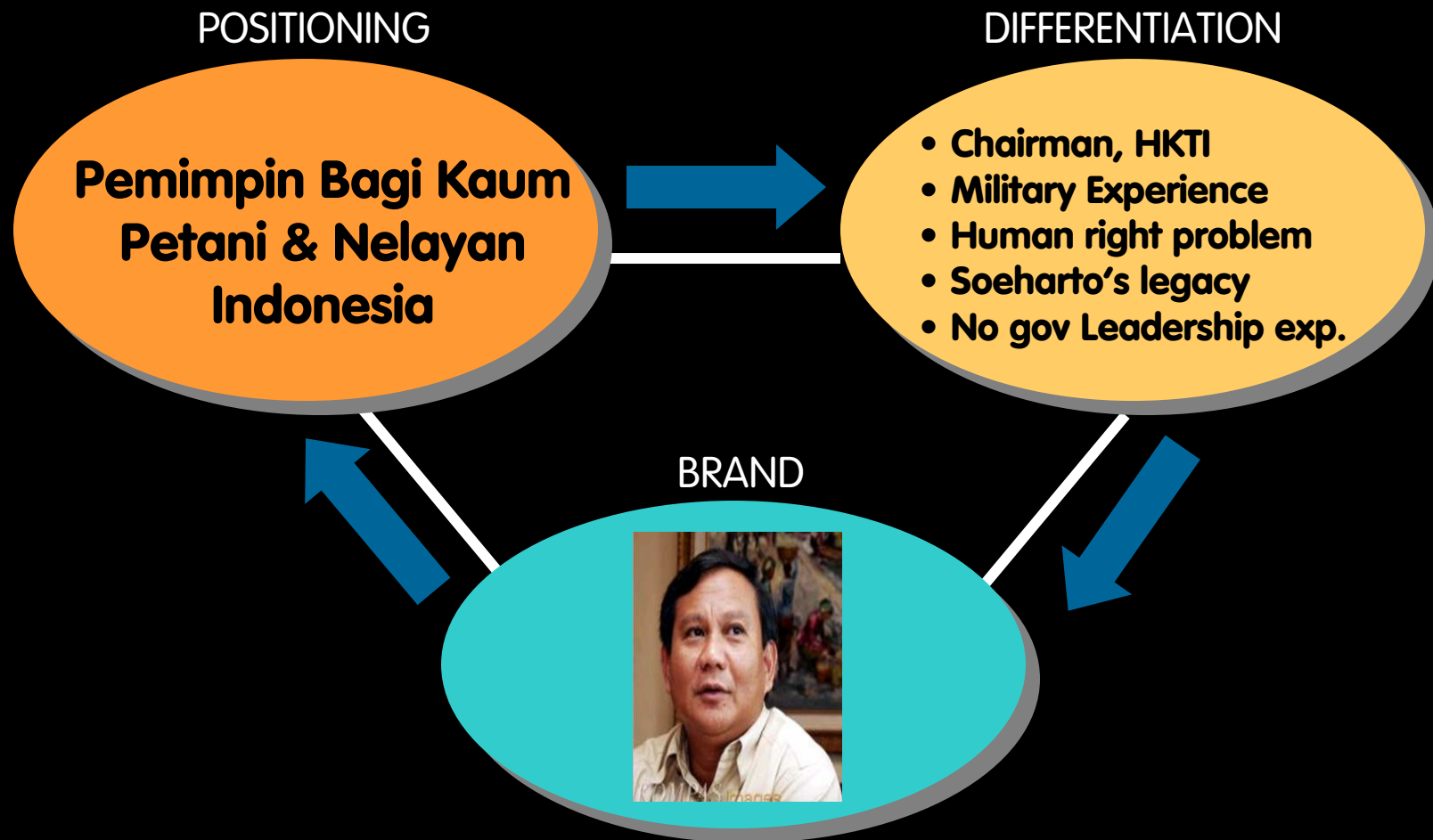

# SBY

POSITIONING

**Proven Incumbent  
with New Hope**

DIFFERENTIATION

- Proven Incumbent
- Charismatic Personality
- Doubter, yet prudent
- Intellectual General
- Not yet proven
- Supported by small party

BRAND

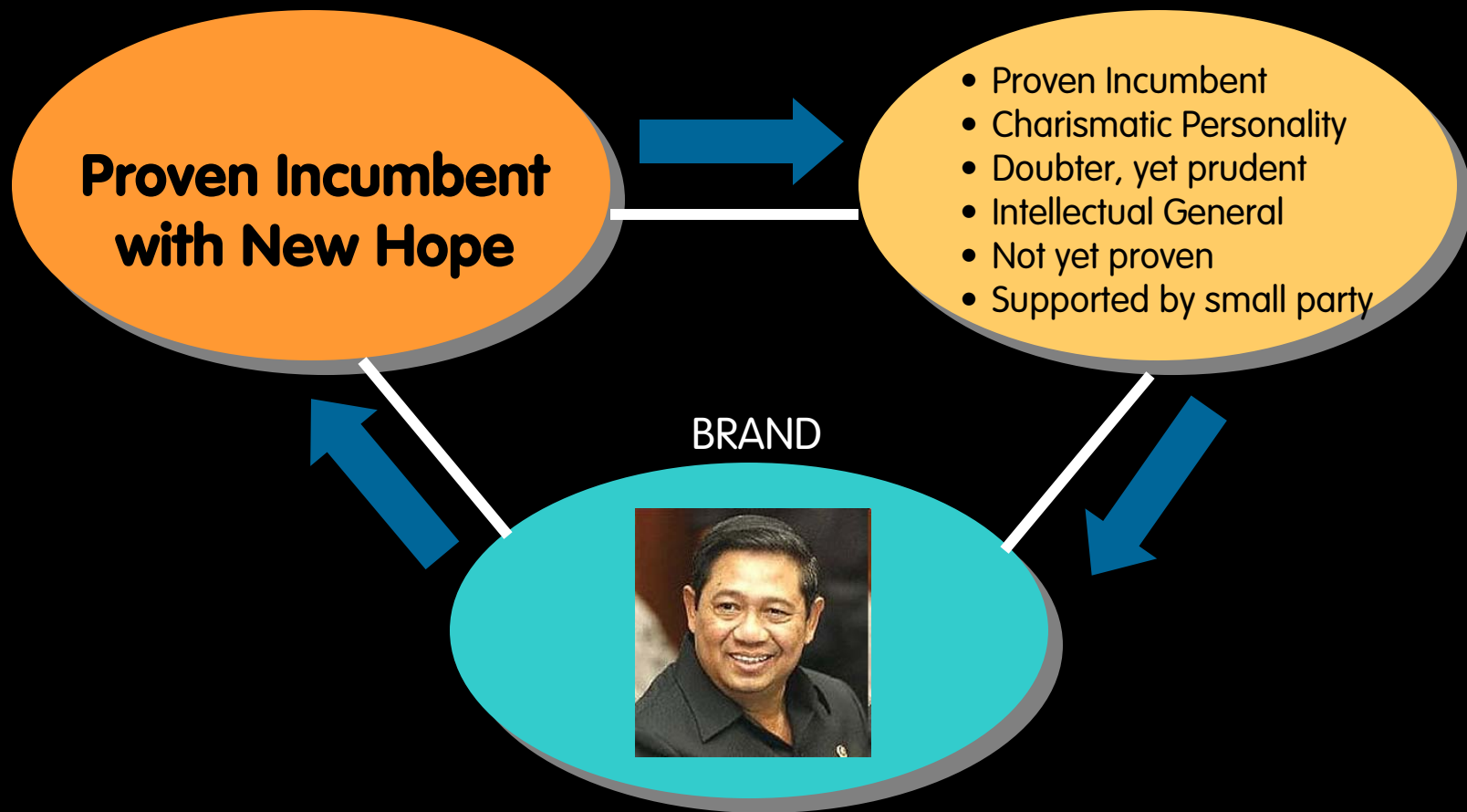

# Wiranto

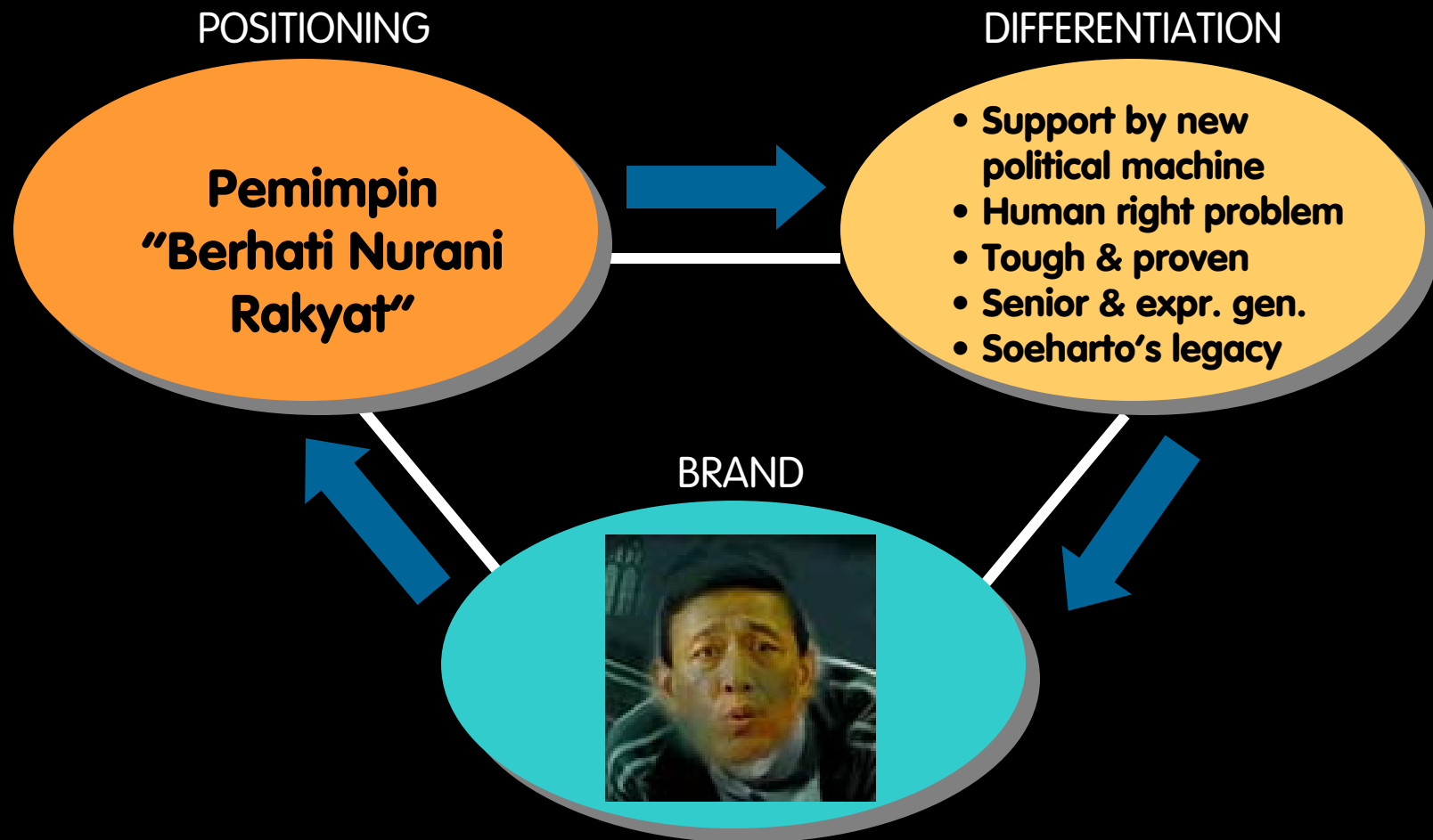

# Soetrisno Bachir

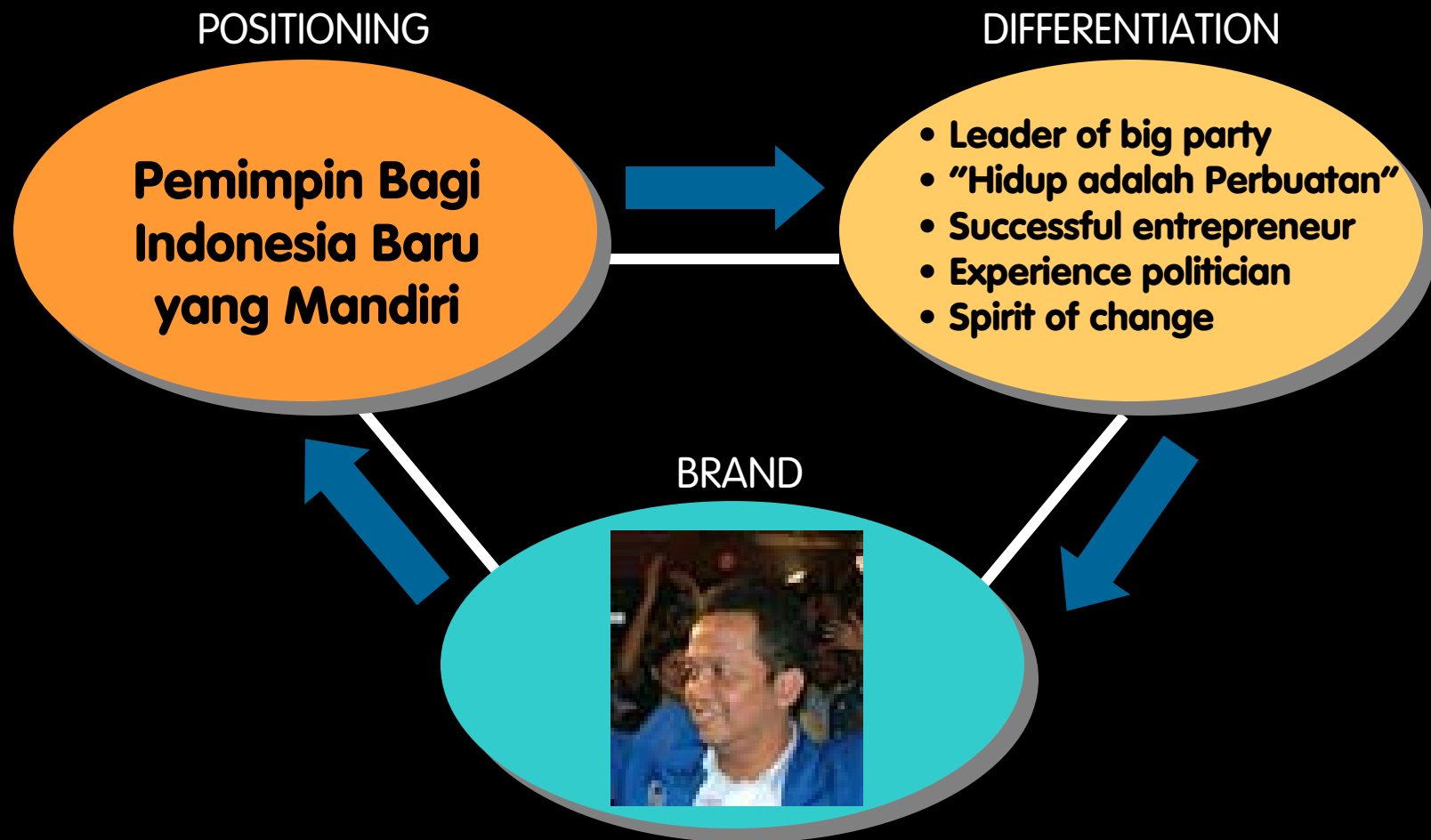



# Rizal Malarangeng



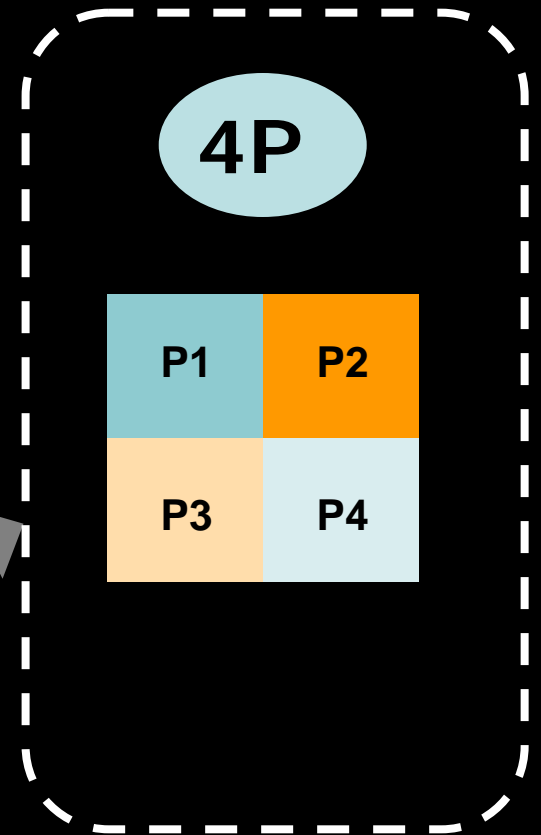
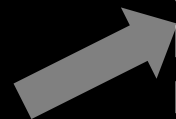
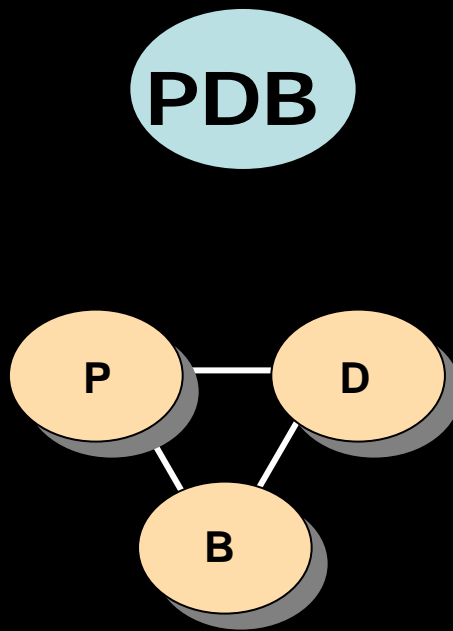
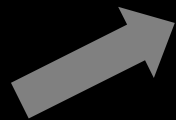
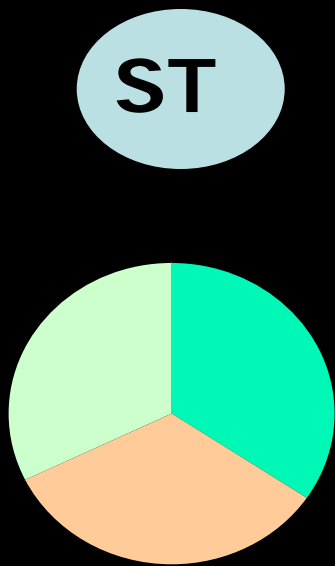

# PROGRAM

P1

P2

P3

P4

VERTICAL

"RATIONAL"

# PROMOTION

HORIZONTAL

"EMOTIONAL"

# SOETRISNO BACHIR



1. Iklan TV, Iklan surat kabar tiga mingguan, billboard di seluruh tanah air.
2. Mengusung tagline: "Hidup adalah perbuatan" dan "Hidup adalah perjuangan".
3. Aktif mengajak para artis-artis untuk bergabung ke partainya dan dicalonkan sebagai caleg.
4. Pesan iklan: Mengajak petani bangkit dan terkesan memasyarakat.
5. Aktif melakukan safari ke daerah-daerah dan mengadakan even-even yang melibatkan artis-artis pendukung PAN.

# PRABOWO

Suka atau tidak, Soeharto adalah salah seorang tokoh kunci dalam sejarah Indonesia pascakolonial. Ia disanjung sekaligus dikecam. Buku ini mengajak kita untuk berpikir ulang mengenai siapa Soeharto dan model kepemimpinan macam apa yang ia kehendaki untuk Indonesia.



— Dr. Baskara T. Wardaya, SJ, *Sejarawan, Direktur PUSdEP (Pusat Sejarah dan Etika Politik) Universitas Sanata Dharma Yogyakarta*

## Prabowo Titisan Soeharto?

Mencari Pemimpin Baru di Masa Paceklik



1. Iklan gencar di hampir seluruh saluran televisi di Indonesia.
2. Saat ini paling populer dibandingkan calon lain karena paling dahulu beriklan di TV.
3. Pesan iklan: Mengajak petani bangkit dan terkesan memasyarakat.
4. Promosi Above the Line (iklan TV) tidak diikuti dengan promosi Below the Line ke daerah-daerah dan langsung ke masyarakat secara memadai.

# DEDE YUSUF

1. Mengusung tema “ Anak Muda Bangkit Memimpin”. Karena masyarakat sudah bosan dengan tokoh lama yang tidak memihak mereka.
2. Penentuan target sasaran juga tepat yaitu, para pendukung cagub-cawagub, pendukung pesaing dan massa mengambang. Dengan pendekatan ke masing-masing target dilakukan customized.
3. Membangun citra yang bagus dimata masyarakat: Aktor yang berwibawa, bijak, tegas, dan bisa memperjuangkan nasib masyarakat Jawa Barat.
4. Promosi above the line (ATL) yang gencar baik di lingkungan tempat tinggal masyarakat dengan leafletnya, spanduk, billboard dan surat kabar.
5. Promosi Below the line (BTL) yang cukup heboh. Banyak digelar kegiatan nyanyi bareng pengamen, pesta dangdut di lingkungan perumahan dan tanah lapang, kumpul bareng di kafe dengan artis.





**AHMAD HERYAWAN  
DEDE YUSUF  
(HADE)**



Thank You  
[www.yuswohady.com](http://www.yuswohady.com)